



6LY2A Series - UTP / STP

Configuration	In-line, 4-stroke, vertical, water-cooled diesel engine		
Max. output at crankshaft	6LY2A-UTP	*264 kW [359 mhp] @3300 rpm	**272 kW [370 mhp] @3300 rpm
	6LY2A-STP	*315 kW [427 mhp] @3300 rpm	**324 kW [440 mhp] @3300 rpm
No. of cylinders	6 cylinder		
Displacement	5.813 L		[354 cu in]
Bore x stroke	106 mm x 110 mm		[4.17 in x 4.33 in]
Aspiration	Turbocharged & intercooled		
Combustion system	Direct injection, in-line pump		
Starting system	Electric starting 12V - 3 kW		
Engine management	Mechanical		
Cooling system	Fresh water cooling by centrifugal fresh water pump		
	Seawater cooling by rubber impeller seawater pump		
Alternator	12V - 80A		
Lubrication system	Enclosed, forced lubricating system		
Engine lube oil specifications	API class: CD or higher, SAE grade: 10W-30 or 15W-40		
Direction of rotation at crankshaft	Counterclockwise (CCW) viewed from stern		
Dry weight without gear	535 kg	[1179 lbs]	
Engine dimensions† L x W x H	1428 x 692 x 736 mm		
Emission compliance	EU: RCD 1, EMC, IMO/GL		
Flywheel housing size	SAE #3		
Controls	Mechanical		

* Fuel temperature 40°C at the inlet of the fuel injection pump [ISO 8665: 2006]

** Fuel temperature 25°C at the inlet of the fuel injection pump (ISO 3046)

†Length measured with KMH60A gearbox & high-riser elbow (Dimensions may vary with other gears/elbow)

NOTE:

Fuel condition: Density at 15°C = 0.84 g/cm³: 1 kW = 1.3596 mhp = 1.3410 HP
 Technical data is according to (ISO 8665)/(ISO 3046)

DIMENSIONS

Rear view

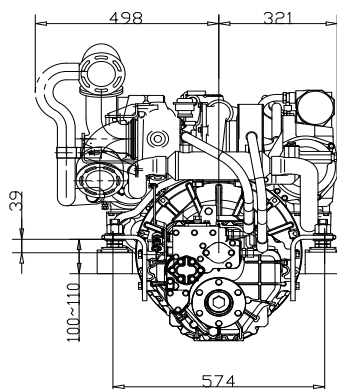

Right side view

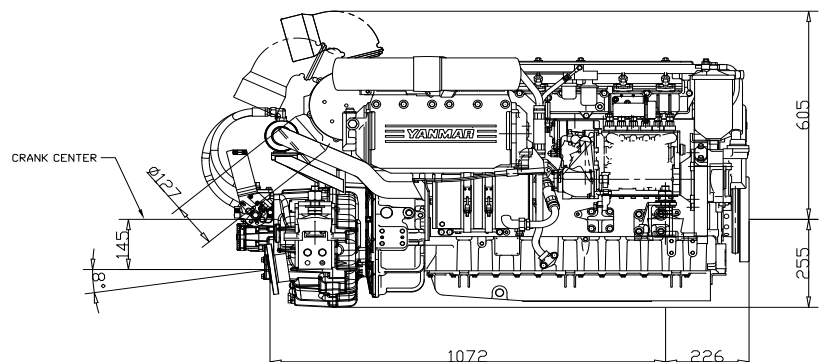

6LY2A with KMH60A marine gear
 (Not to be used for engine installation)



PERFORMANCE CURVES

6LY2A-UTP Torque curve

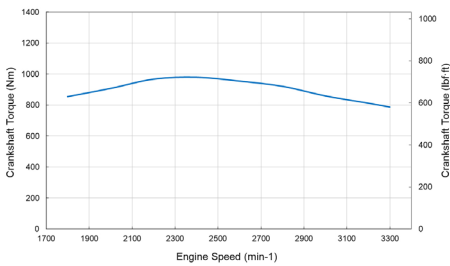

6LY2A-UTP Output Power curve

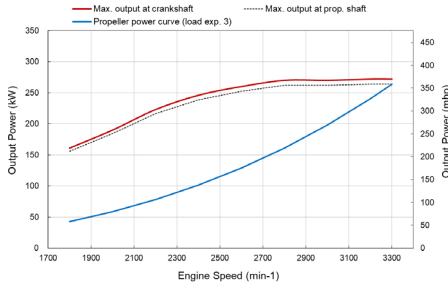

6LY2A-UTP Torque curve

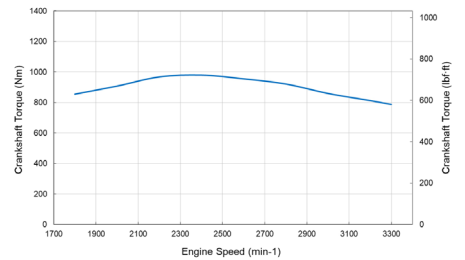

6LY2A-STP Torque curve

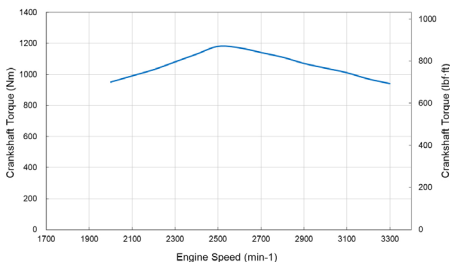

6LY2A-STP Output Power curve

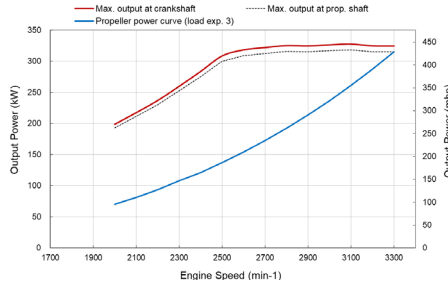

6LY2A-STP Fuel consumption (load exp. 3)

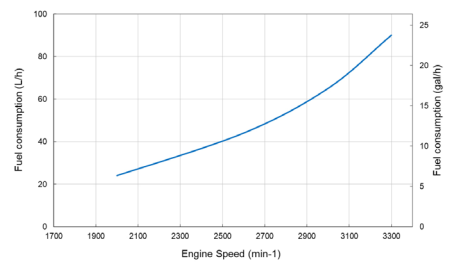

MARINE GEAR*

Model	KMH60A [down angle 8°]	ZF280-1 [parallel]	ZF280-1A
Clutch type	Hydraulic multi-disc	Hydraulic multi-disc	Hydraulic multi-disc
Dry weight**	76 kg [168 lbs]	86 [190 lb]	86 [190 lb]
Reduction ratio [fwd/asn]	1.55/1.55	2.04/2.04	2.43/2.43
Direction of rotation [viewed from stern]	Clockwise or counterclockwise	Clockwise or counterclockwise	Clockwise or counterclockwise
Lubrication system	Forced lubrication	Forced lubrication	Forced lubrication
Lube oil specifications	API class: CF or higher, SAE grade: #30	API class: CF or higher, SAE grade: #30	API class: CF or higher, SAE grade: #30
Max. lube oil capacity (L)	2.8 L	4.5 L	4.5 L
Dry weight - engine & gear	611 kg [1347 lbs]	621 kg [1369 lbs]	621 kg [1369 lbs]

* Other marine gearboxes and configurations available upon request. Contact your local supplier for more information.

**Dry weight of Kanzaki marine gear with SAE #3 Flange, including Foot, Cooler & Damper

ACCESSORIES

Standard engine package

- Exhaust mixing elbow [L-type]
- Alternator 12V - 80A
- 3G instrument panel

Optional accessories

- High-riser mixing elbow [instead of L-elbow]
- Flexible mounts Barry
- Flexible mounts Bridgestone
- Extension wire harness [3m, 5m, 10m, 20m]
- Sensor for VDO instrument panels
- SOLAS including Certificate [factory fit only]

- Lub oil evacuation pump
- Water separator

NOTE: All data subject to change without notice. Text and illustrations are not binding.