



6LY2M Series - WDT / WST

Configuration	In-line, 4-stroke, vertical, water-cooled diesel engine		
Max. output at crankshaft*	6LY2M-WDT	243 kW @3200 rpm	[330 mhp @3200 rpm]
	6LY2A-WST	277 kW @3200 rpm	[376 mhp @3200 rpm]
No. of cylinders	6 cylinder		
Displacement	5.813 L		[354 cu in]
Bore x stroke	106 mm x 110 mm		[4.17 in x 4.33 in]
Aspiration	Turbocharged & intercooled		
Combustion system	Direct Injection, in-line Pump		
Starting system	Electric starting 12V - 3 kW		
Engine management	Mechanical		
Cooling system	Fresh water cooling by centrifugal fresh water pump		
	Seawater cooling by rubber impeller seawater pump		
Alternator	12V - 80A		
Lubrication system	Enclosed, forced lubricating system		
Engine lube oil specifications	API class: CD or higher, SAE grade: 15W-40		
Direction of rotation at crankshaft	Counterclockwise (CCW) viewed from stern		
Dry weight without gear	535 kg	[1179 lbs]	
Engine dimensions† L x W x H	1412 x 835 x 880 mm		
Emission compliance	EU: IMO Tier2	US:	
Flywheel housing size	SAE #3		
Controls	Mechanical		

* Fuel temperature 40°C at the inlet of the fuel injection pump [ISO 8665]

†Length includes YX-50S gearbox & high-riser elbow (Dimensions may vary with other gears/elbow)

NOTE:

Fuel condition: Density at 15°C = 0.84 g/cm³; 1 kW = 1.3596 mhp = 1.3410 HP
Technical data is according to (ISO 8665)

DIMENSIONS

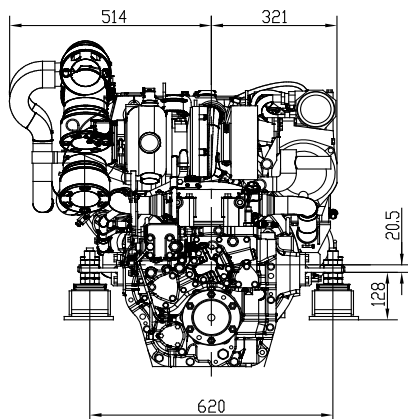
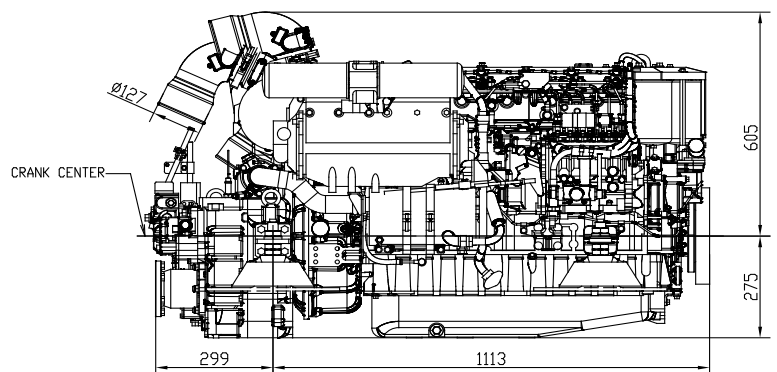
Rear view**Right side view**

6LY2M-WDT/WST with YX-50S gearbox
(Not to be used for engine installation)



PERFORMANCE CURVES

6LY2M-WDT Torque curve

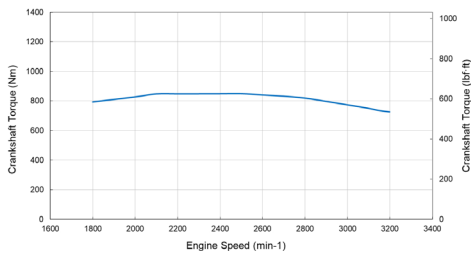

6LY2M-WDT Output Power curve

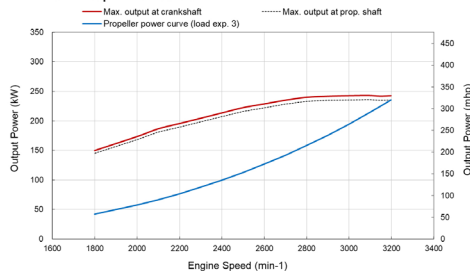

6LY2M-WDT Fuel consumption (load exp. 3)

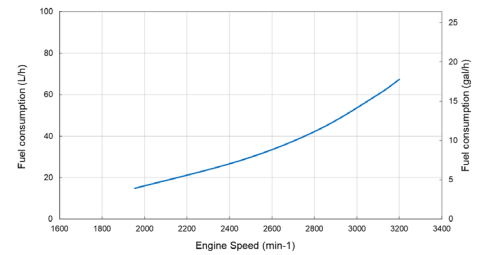

6LY2M-WST Torque curve

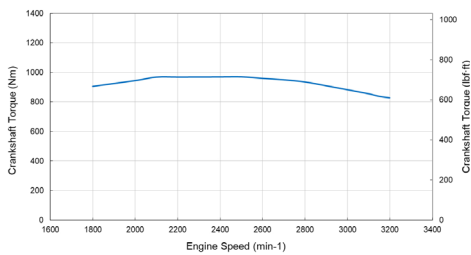

6LY2M-WST Output Power curve

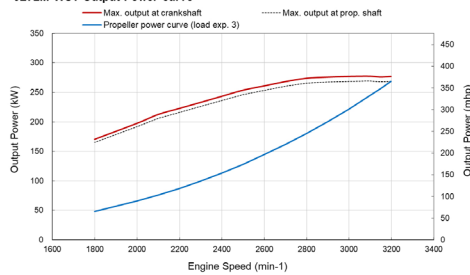

6LY2M-WST Fuel consumption (load exp. 3)

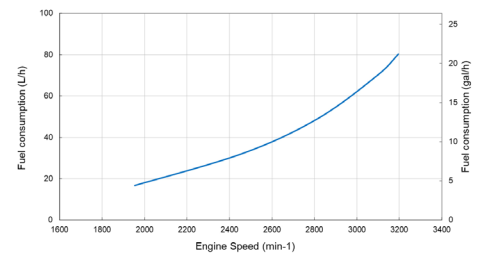

MARINE GEAR*

Model	YX-50S [-1]			
Clutch type	Hydraulic multi-disc			
Dry weight	108 kg [238 lbs]			
Reduction ratio [fwd/asn]	1.51	2.03	2.48	2.88
Direction of rotation [viewed from stern]	Clockwise or counterclockwise			
Lubrication system	Forced lubrication			
Lube oil specifications	SAE #30			
Max. lube oil capacity	4.5			
Dry weight - engine & gear	643 kg [1418 lbs]			

* Other marine gearboxes and configurations available upon request. Contact your local supplier for more information.

ACCESSORIES

Standard package

- Exhaust mixing elbow [L-type]
- 12V electric system
- Alternator 12V - 80A
- 3G instrument panel (B, C or D size)
- Engine stop device
- Deep sump

Optional accessories

- High-riser mixing elbow [instead of L-elbow]
- Flexible mounts Barry
- Flexible mounts Bridgestone
- Extension wire harness [3m, 5m, 10m, 15m]
- 2nd station extension wire harnesses [3m, 5m, 10m, 20m] Sensor for VDO

- Semi 2-pole
- 24V electric system
- Lubrication oil evacuation pump
- Water separator
- Trolling valve [only for KMH60A]
- Duplex on-engine fuel filter

NOTE: All data subject to change without notice. Text and illustrations are not binding.